

emcogroup

Designed for your profit



MAXXMILL 400 – 630 – 750

Vertical milling center
for 5-sided machining

MILLING
EMCO-WORLD.COM

MAXXMILL 400

Compact vertical milling centre

MAXXMILL 400 is the ideal vertical milling centre for complex 5-axis machining of small workpieces in small or medium quantities. Is suited for perfectly tool and mould making, mechanical, precision and medical engineering, optical industry, contract manufacturing and further education facilities.

1 MACHINE BED

- Machine bed and slide systems made of solid welded steel and cast iron components

2 TOOL MAGAZINE

- Tool changer with 30 tool stations

3 SPINDLE

- Mechanical spindle direct drive: 12000 rpm
- Water-cooled motor spindle: 24000 rpm

4 CONTROL

- State-of-the-art touch screen control technology from Siemens - Siemens 840D sl or Heidenhain - TNC 620
- emcoNNECT available for Siemens Sinumerik 840D sl

5 CONTROL PANEL

- Ergonomically positioned and swivelling control panel

6 TABLE

- Massive swivel-rotary table with \varnothing 400 mm

7 CHIP REMOVAL

- The chips can be removed by an optional available hinge type chip conveyer





Swivel-rotary table. The swivel-rotary table has a flexible clamping surface with a diameter of 400 mm and can be loaded with 80 kg. A workpiece with a maximum edge length of 250 x 250 x 225 mm can be processed on 5 sides with optimum results.

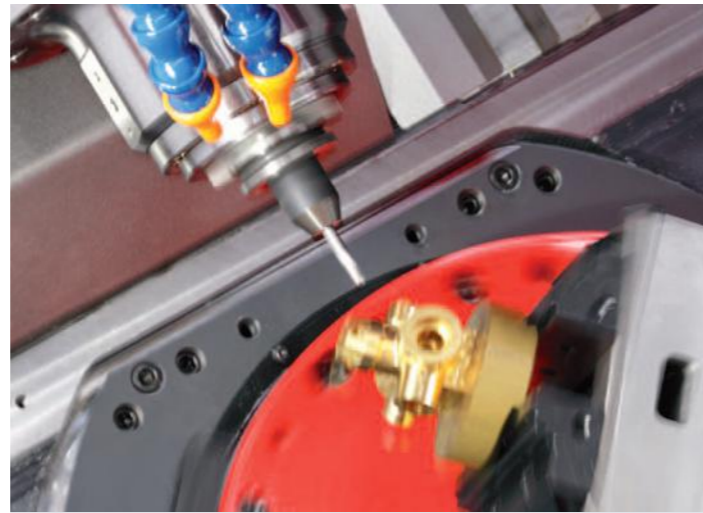

Swivel range. With +/- 100° swivel range the B-axis provides a larger work area compared with the products from other manufacturers. The C-axis can be rotated by 360° without limitation.



Heidenhain TNC 620. The TNC 620 is a compact but versatile contouring control for up to five controlled axes. Thanks to its flexible operating concept—workshop-oriented programmability with HEIDENHAIN conversational programming or off-line programming—and its scope of features, it is especially suited for use on milling machines.



Sinumerik 840D sl incl. Shopmill. Sinumerik 840D sl incl. Shopmill: The Sinumerik 840D sl incl. Shopmill is a universal and flexible CNC system and offers free contour programming, Moving cycles for complex contours, fast reference point setting with touch probe systems, tilting the working plane, Cylindrical surface machining, 3-D tool compensation, fast execution through short block processing times.



Tool magazine. Is equipped with 30 tool stations. At the version with 24.000 U/min the spindle has a HSK-A40 recording.

MAXXMILL 400 Technical Highlights

Highlights

- 5-axis machining in a single set-up
- Top thermostability
- Top machining precision
- Modern moving column concept
- Massive swivel-rotary table with \varnothing 400 mm provides high stability and precision
- Compact machine design
- Cutting-edge control technology from Siemens or Heidenhain
- emcoCONNECT for Siemens 840D sl
- Extensive options such as water-cooled motor spindle with 24000 rpm
- Optimal chip removal
- Attractive price-performance ratio
- Made in the Heart of Europe

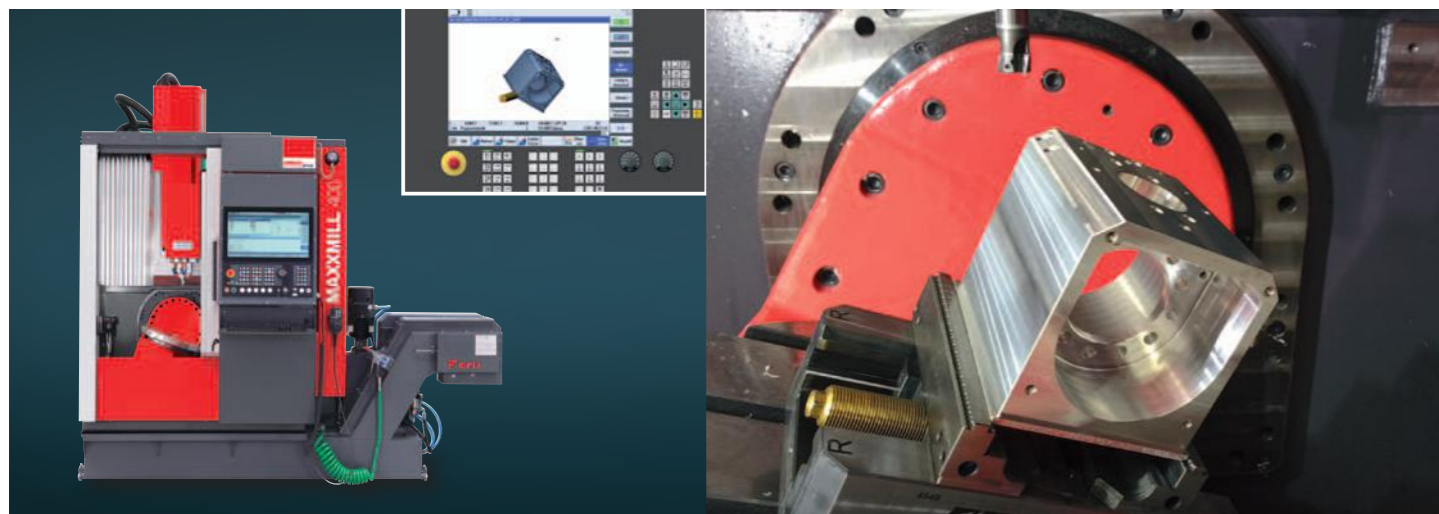

For Industrial Training: Maxxmill 400 with SinuTrain includes beside to the machine and 18 licenses for SinuTrain and Sinumerik Operate, 20 users for EMCO Campus and accessories ready for use. The illustration of the operator panel front, machine control panel and user interface correspond to the original design, which allows for real operation. The user interface corresponds to the original SINUMERIK Operate interface. The simulation is identical with the real control. The full functionality of SINUMERIK Operate on SINUMERIK 840D sl/828D is available.

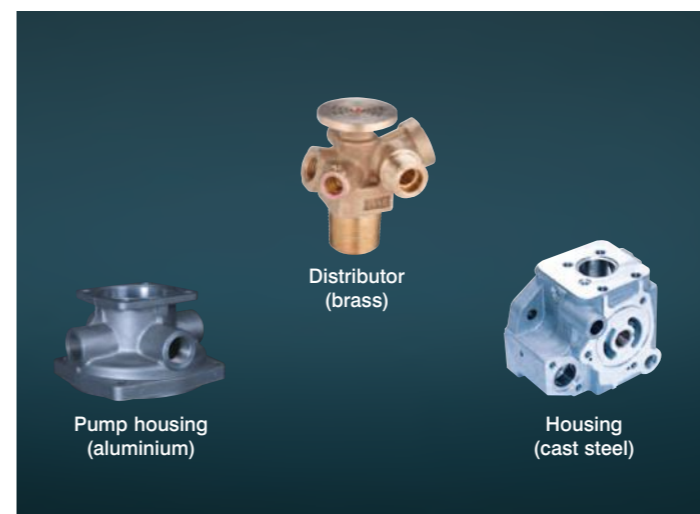

Workpieces of 250 x 250 x 225 mm with a weight of up to 80 kg can be machined with the MaxxMill 400 in one setting on 5 sides.

MAXXMILL 630

Compact vertical milling center

The new CN vertical milling center Maxxmill 630 is capable to mill parts with an edge size of 445 x 445 x 290 mm in just one operation in an efficient and precise way. Its compact design in cast iron and welded steel guarantees the maximum in rigidity and thermosymmetry. Short power flows assure the highest precision and an excellent surface quality of the workpiece.

1 MACHINE BASE

- The machine base consists of welded steel construction, the X-Y slide and the Z-axis are cast iron.

2 TOOL CHANGER

- Tool changer with 30 tool stations
- 60-fold chain magazin optional available

3 SPINDLE

- Mechanical spindle direct drive: 12000 rpm
- Motor spindle: 15000 rpm

4 OPERATING PANEL

- Available with Heidenhain or Siemens touch screen control technology
- 90° Swivelling operating panel
- emcoNNECT available for Siemens Sinumerik 840D sl

5 TABLE

- Swivelling-rotary table

6 CHIP REMOVAL

- The chip removal can be handled by an optional available hinge type chip conveyer.



Housing
(Cast steel)



Coupling
(Steel)

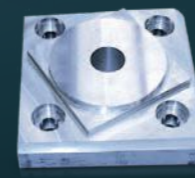

Test piece
(Aluminium)

MAXXMILL 750

Compact vertical milling center

The new CNC vertical milling center Maxxmill 750 is capable to mill parts with an edge size of 530 x 530 x 417 mm in just one operation in an efficient and precise way. Its compact design in cast iron and welded steel guarantees the maximum in rigidity and thermosymmetry. Short power flows assure the highest precision and an excellent surface quality of the workpiece. At the new Maxxmill 750, with its long Y-axis, large linear guides and the ability to machine workpieces up to a maximum weight of 300 kg, optimum conditions were created for the production.

1 MACHINE BASE

- The machine base consists of welded steel construction, the X-Y slide and the Z-axis are cast iron.

2 TOOL CHANGER

- Tool changer with 30 tool stations
- Tool changer with 40 or 60 tool stations as option available

3 SPINDLE

- Mechanical spindle direct drive: 12000 rpm
- Motor spindle: 15000 rpm

4 OPERATING PANEL

- Available with Heidenhain or Siemens touch screen control technology
- 90° Swivelling operating panel
- emcoCONNECT available for Siemens Sinumerik 840D sl

5 TABLE

- Swivelling-rotary table
- Optional with counter bearing for enhanced stability

6 CHIP REMOVAL

- The chip removal can be handled by an optionally available hinge type chip conveyer.
- Air or water for the chip removal is available as option.

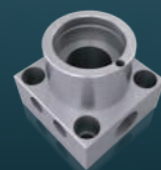

Screw support
(Steel)



Distributor
(Brass)

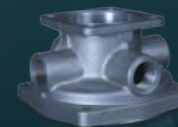

Pump housing
(Aluminium)



Swivel-rotary table. The swivel-rotary table has a large clamping area of 630 x 500 mm (24.8 x 19.6") resp. 750 x 600 mm (29.5 x 23.6") and can bear loads of up to 200 kg (440.9 lb) resp. 300 kg (661.3 lb). This makes it possible to simply machine workpieces with an edge size of 445 x 445 x 290 mm (17.5 x 17.5 x 11.4") or 530 x 530 x 417 mm (20.8 x 20.8 x 16.4"). The special shape of the table allows the spindle nose to move closer to the table center.

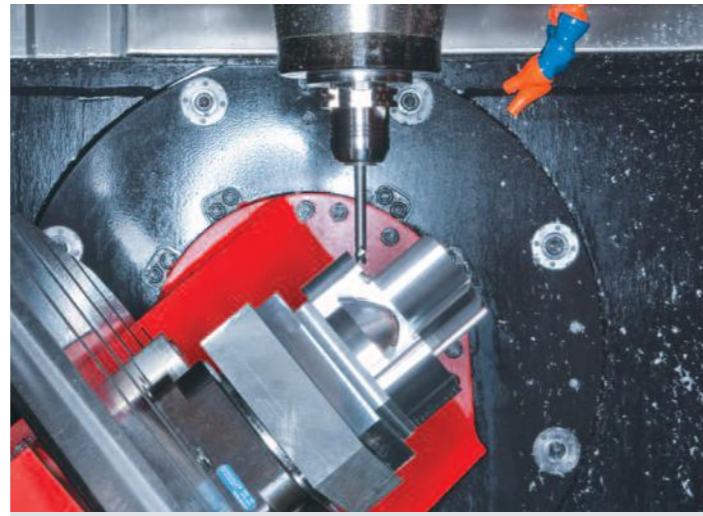

Travel range. With a travel range of +/- 100°, the B axis provides a larger work area than most products from other manufacturers. The C axis can be infinitely rotated by 360°.



The Sinumerik 840D sl incl. Shopmil. The Sinumerik 840D sl incl. Shopmil is a universal and flexible CNC system and offers free contour programming, milling cycles for complex contours, fast reference point setting with touch probe systems, tilting the working plane, cylindrical surface machining, 3-D tool compensation, fast execution through short block processing times.



Heidenhain TNC 620. The TNC 620 is a compact, adaptable control for up to five controlled axes. With its flexible operating concept - workshop-oriented programmability in the HEIDENHAIN Klartext dialog or external programming - and its scope of performance, it is perfectly suited for EMCO milling centers.

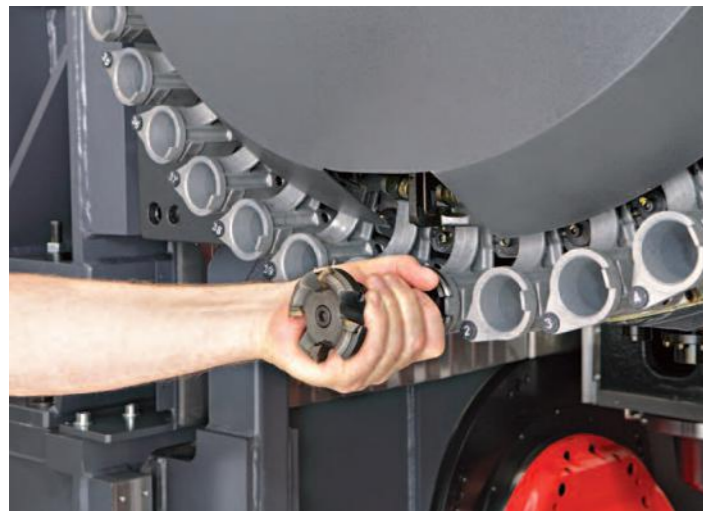

Tool changer. The tool changer of the Maxxmill 630 is a drum magazine for 30 tools (60 tools chain type magazine as option). For Maxxmill 750, a tool magazine with 40 or 60 tool stations is available as option. The tools are managed according to the variable tool station coding principle (random), which means that tools are always deposited in the first free magazine station for time reasons.

MAXXMILL 630 / 750 Technical Highlights

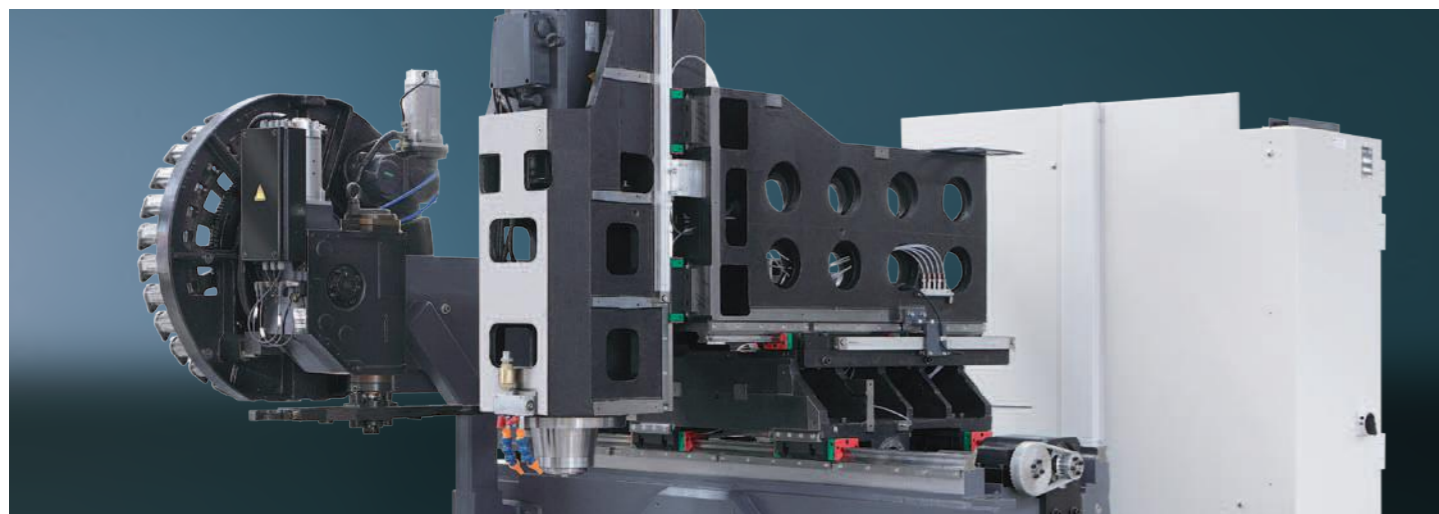

Massive structure. The carriage, slide and machining head are made of cast iron for maximum stability and best workpiece finishing. Cast components are optimized by means of FEM analysis, which means that these components are lightweight and stable at the same time.



The direct drive on the Z-axis stands for highest accuracy and prevents any reverse of pulleys or belts.

Highlights

- 5-sided machining in a single set-up
- Top thermostability
- Top machining precision
- Modern moving column concept
- Massive tilting rotary table 750 x 600 mm (29.5 x 23.6") / 630 x 500 mm (24.8 x 19.7") provides high stability and precision
- Compact machine design
- Cutting-edge control technology from Siemens or Heidenhain
- emCONNECT available for Siemens Sinumerik 840D sl
- Extensive options such as water-cooled motor spindle with 15000 rpm
- Optimal chip removal
- Attractive price-performance ratio
- Made in the Heart of Europe

Your “Control Center” for the entire production flow

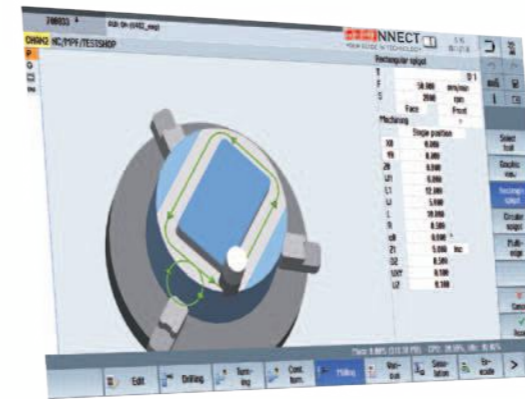

SINUMERIK - the Control and the Machine's Centerpiece

Thanks to the App Launcher operators may switch between the emcoNNECT Apps and the control at any time. All it takes to do so is a click on the emcoNNECT logo. To improve the work processes on the machine the control can, as shown in the picture, be operated in full screen mode or in interaction with practical apps (sidebar).

DASHBOARD – For a Quick Overview of the Machine Status

Clear and compact processing of all relevant machine and NC data depending on the configuration of the machine (number of tool systems, spindles, ...) and the active operating mode (JOG, MDA, AUTO). Know at a glance whether everything is OK or whether the machine operator will be required to interact.

MACHINE DATA – All Data related to Productivity at a Glance

Operating data collection to inform the user about the current production status and OEE (Overall Equipment Effectiveness) values full screen or sidebar.



emcoNNECT's hardware basis is a 22" industrial touch control panel combined with an industrial PC (IPC).

Highlights

- Direct interaction between EMCO Apps and the control
- Intuitive user interface optimized for touch control
- Range of available applications is continuously being expanded
- Customised and project-specific applications
- Optimized for the EMCO machine range
- emcoNNECT allows for easy and quick configuration and updating

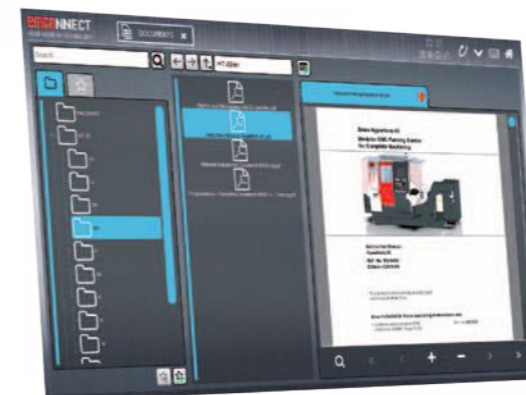

DOCUMENTS – A Digital and Expandable Document Collection Customised to Suit Your Individual Needs

To display PDF documents such as machine documentations, programming instructions, process descriptions ... Including favourites management - full screen or sidebar

Installation plan MM 400

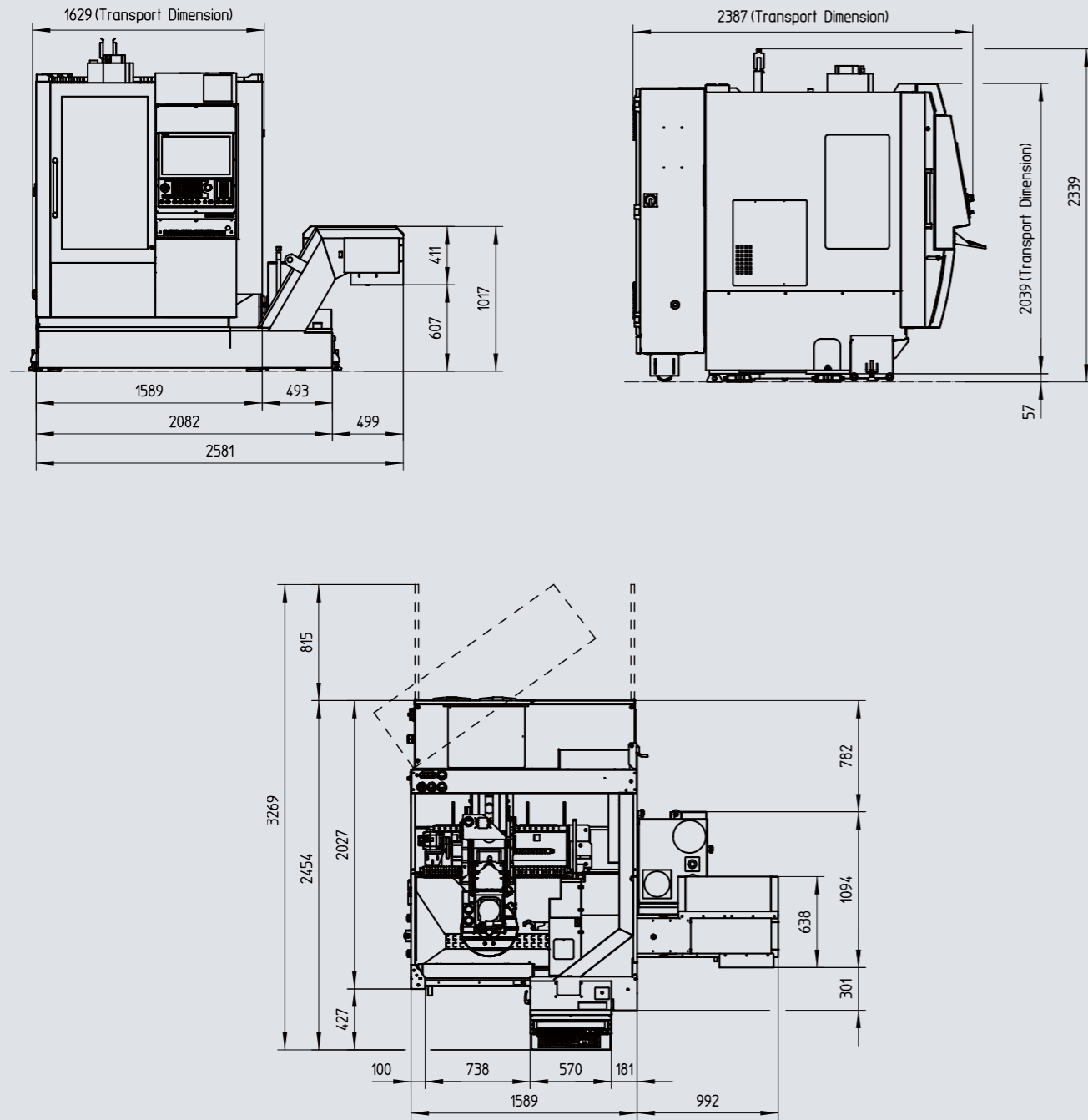

Installation plan MM 630

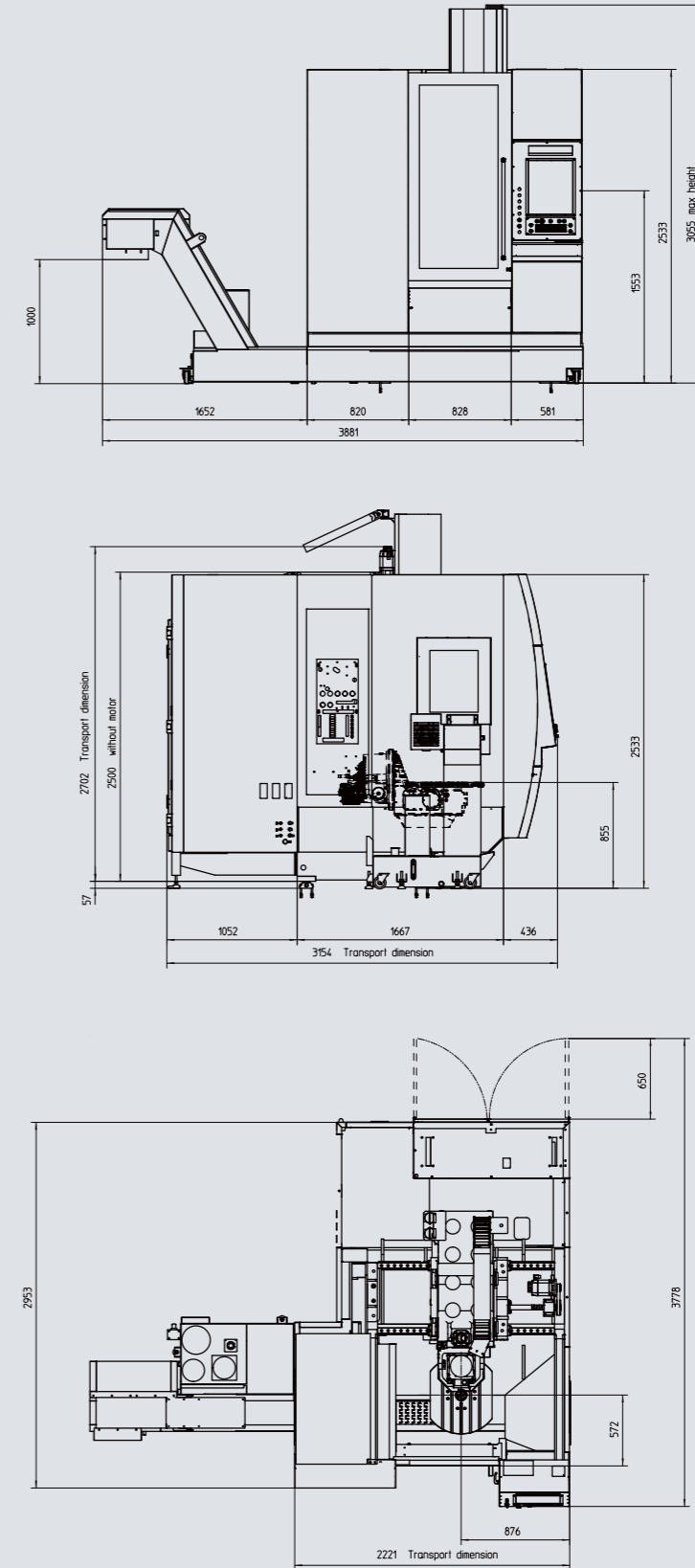

Installation plan MM 750

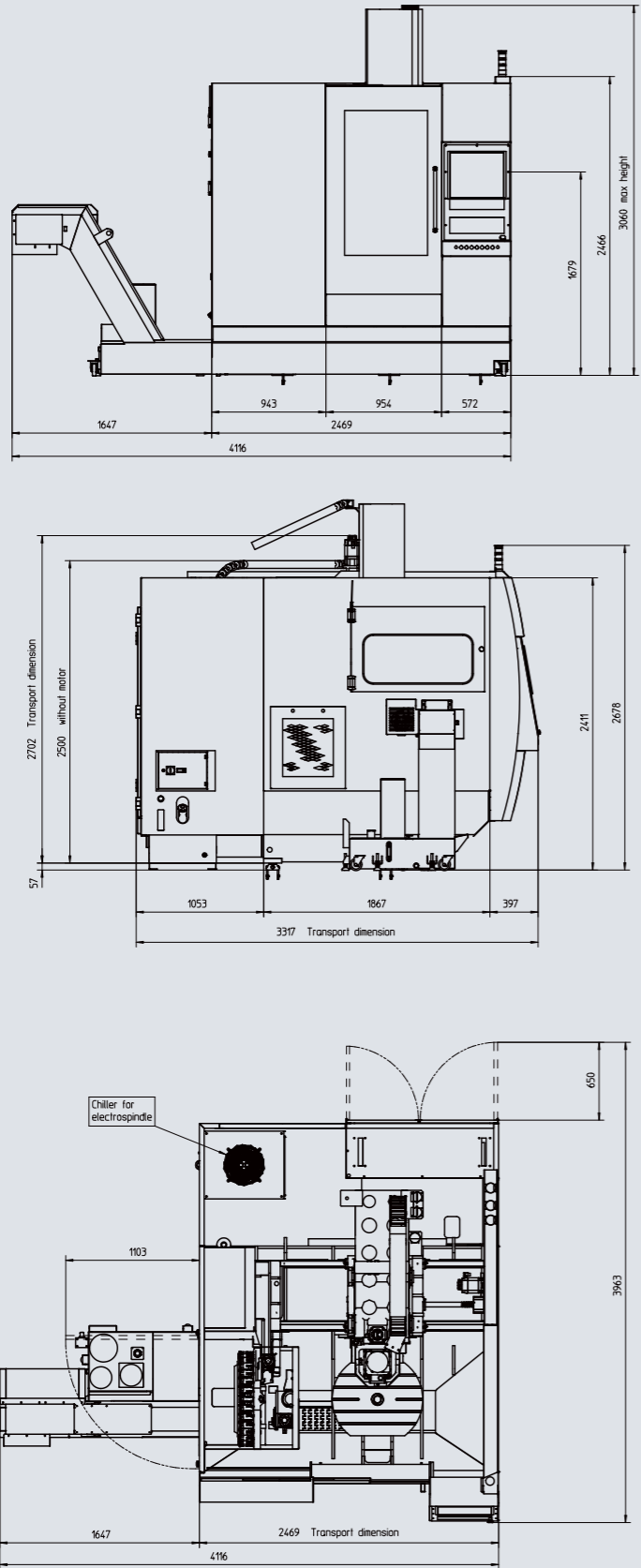

Work area MM 400

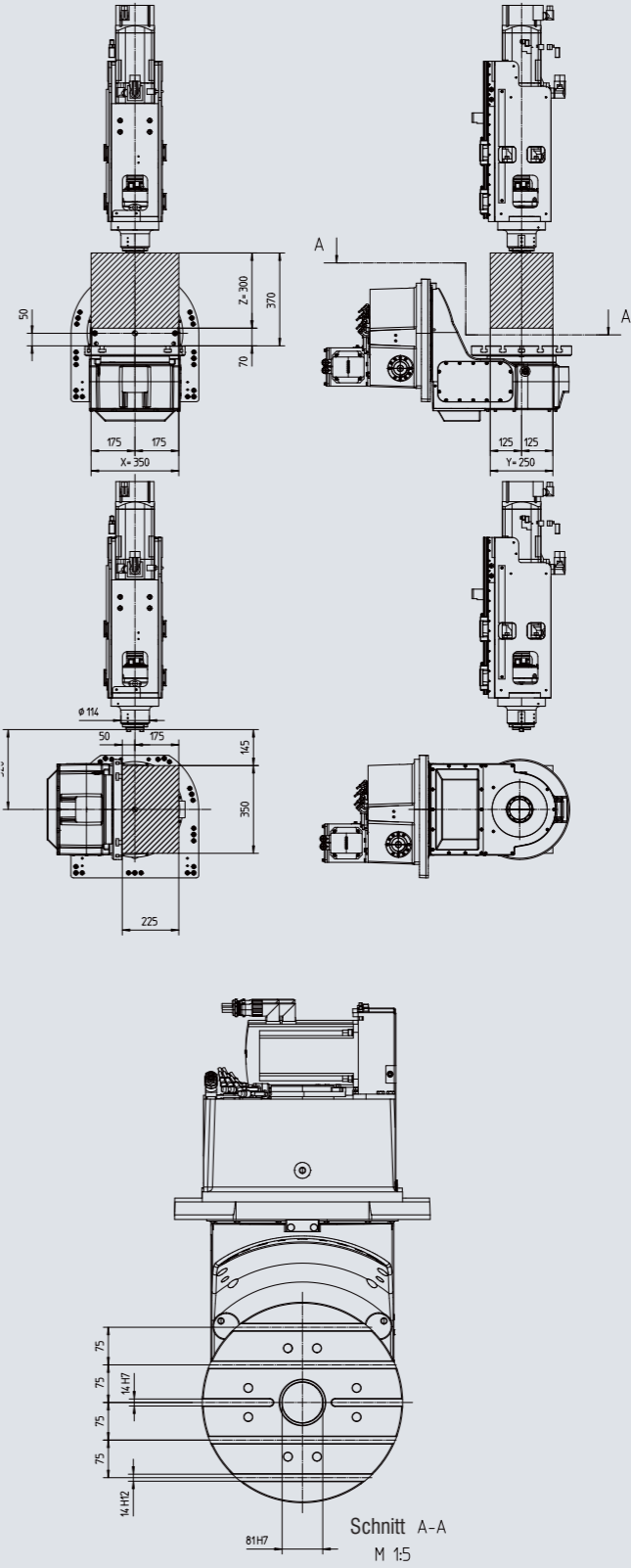

Work area MM 630

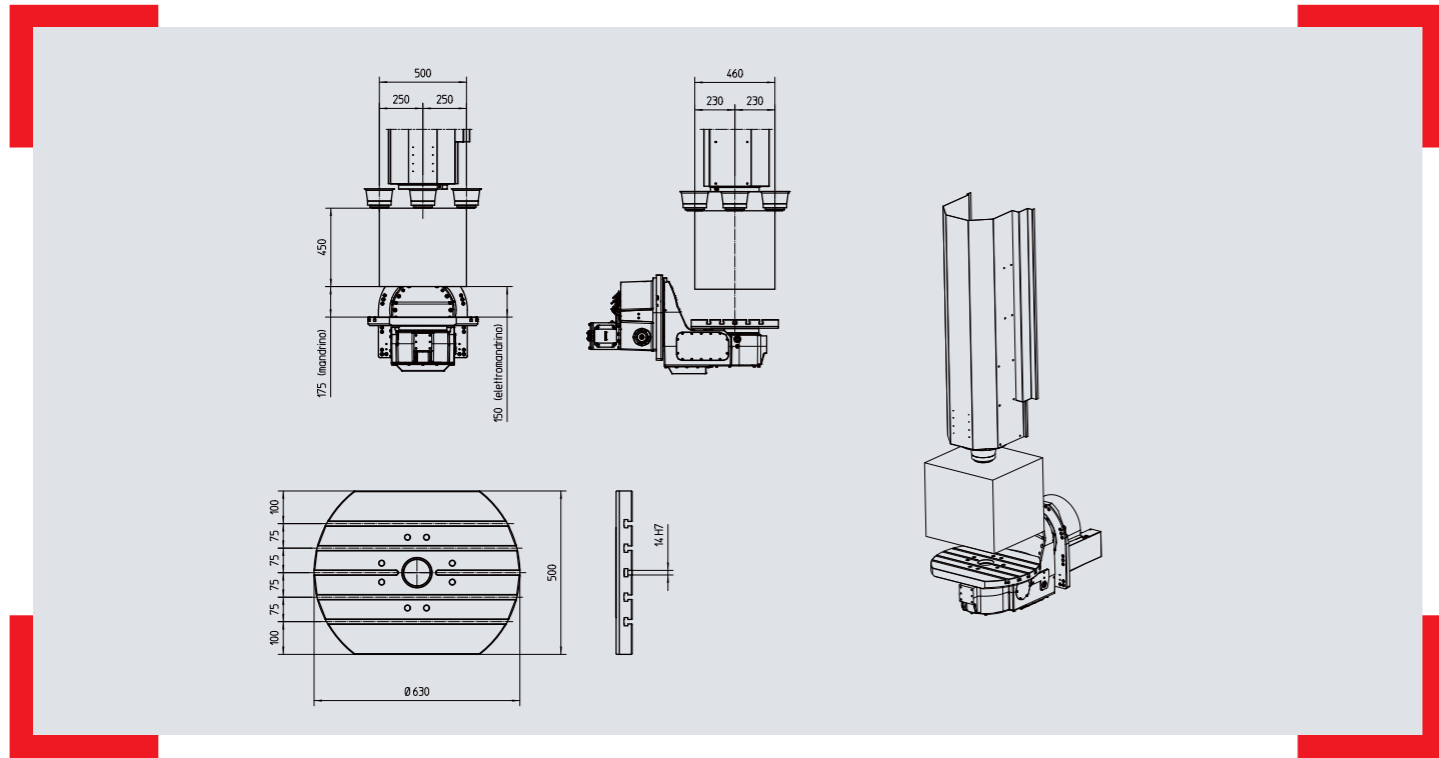

Work area MM 750

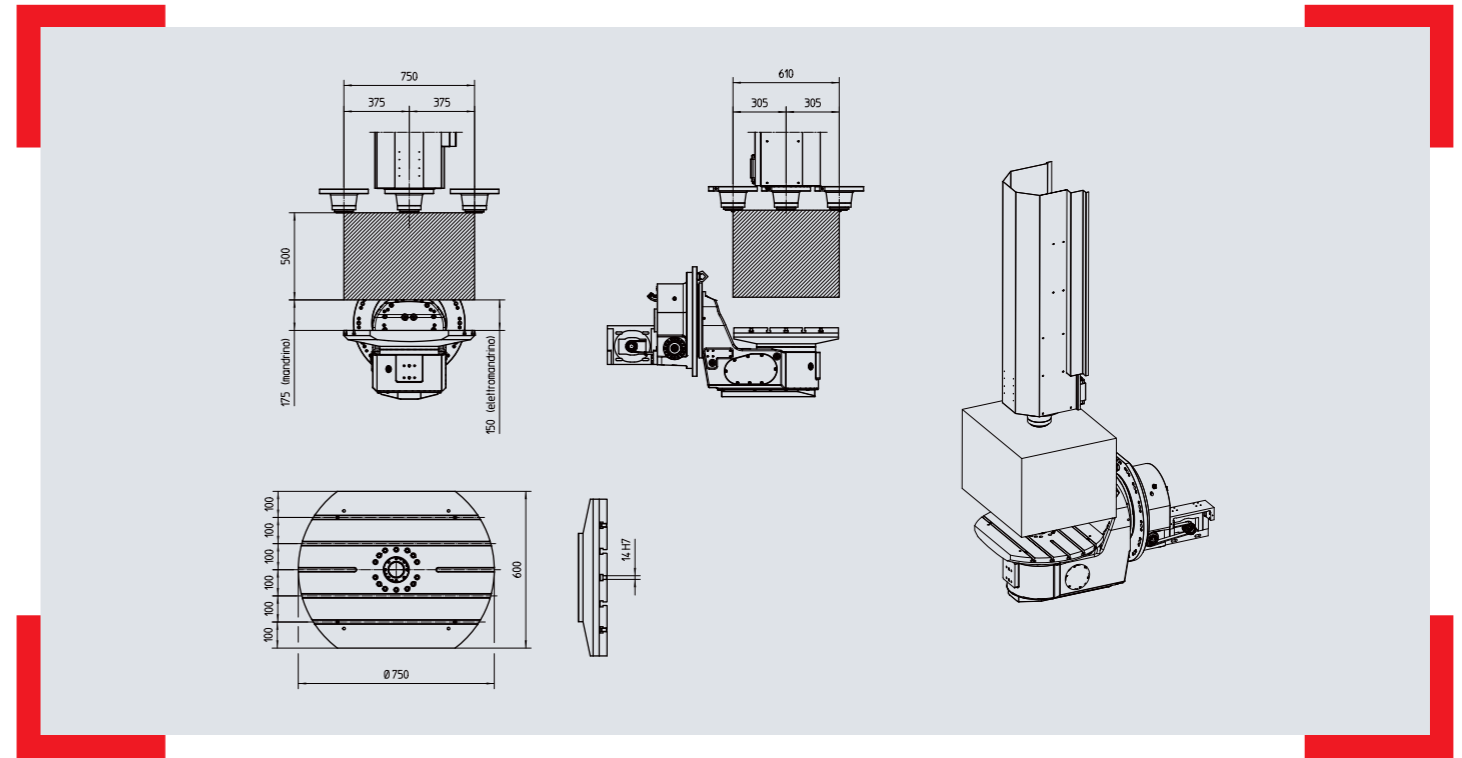

Work area

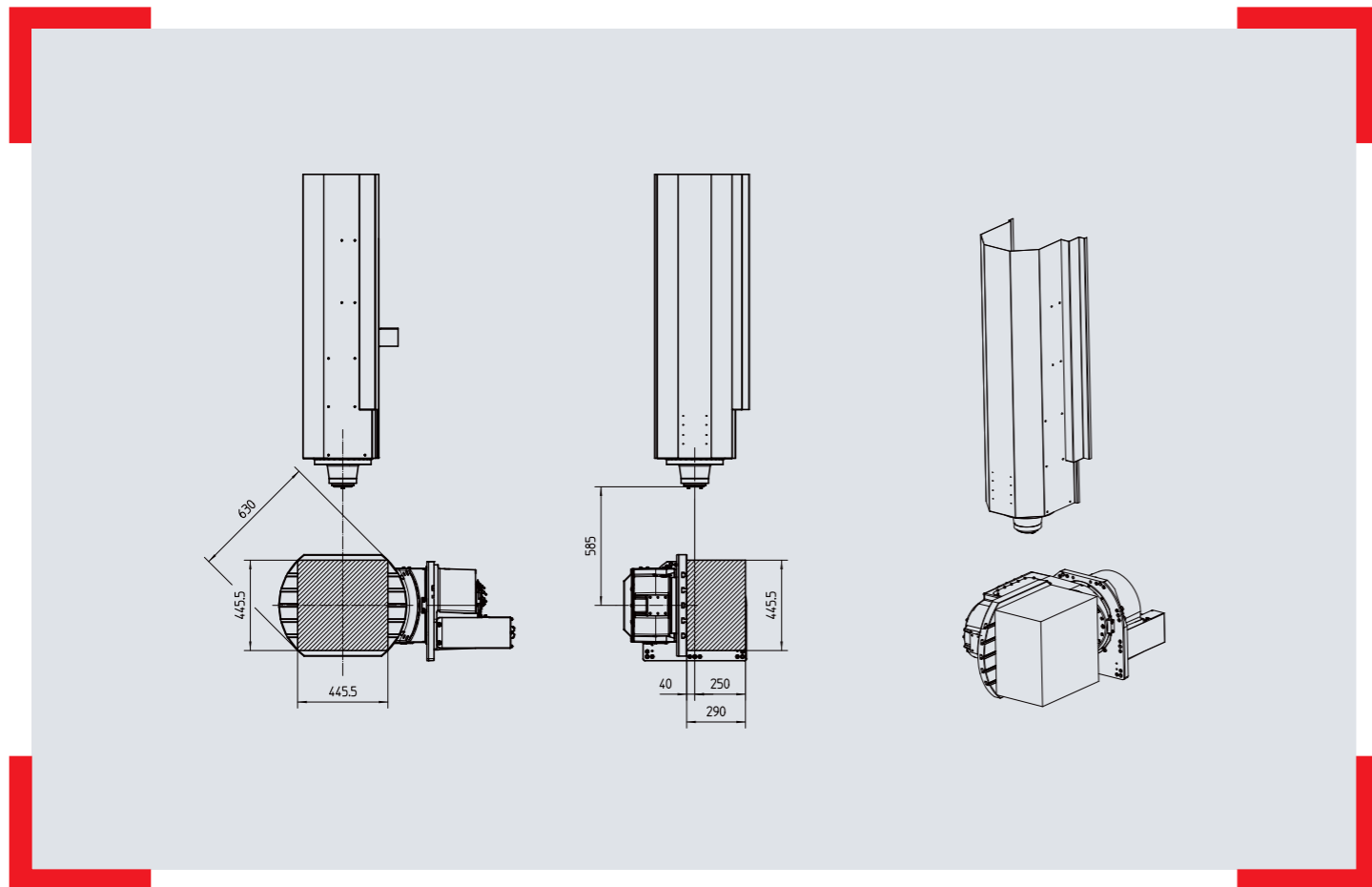

Work area

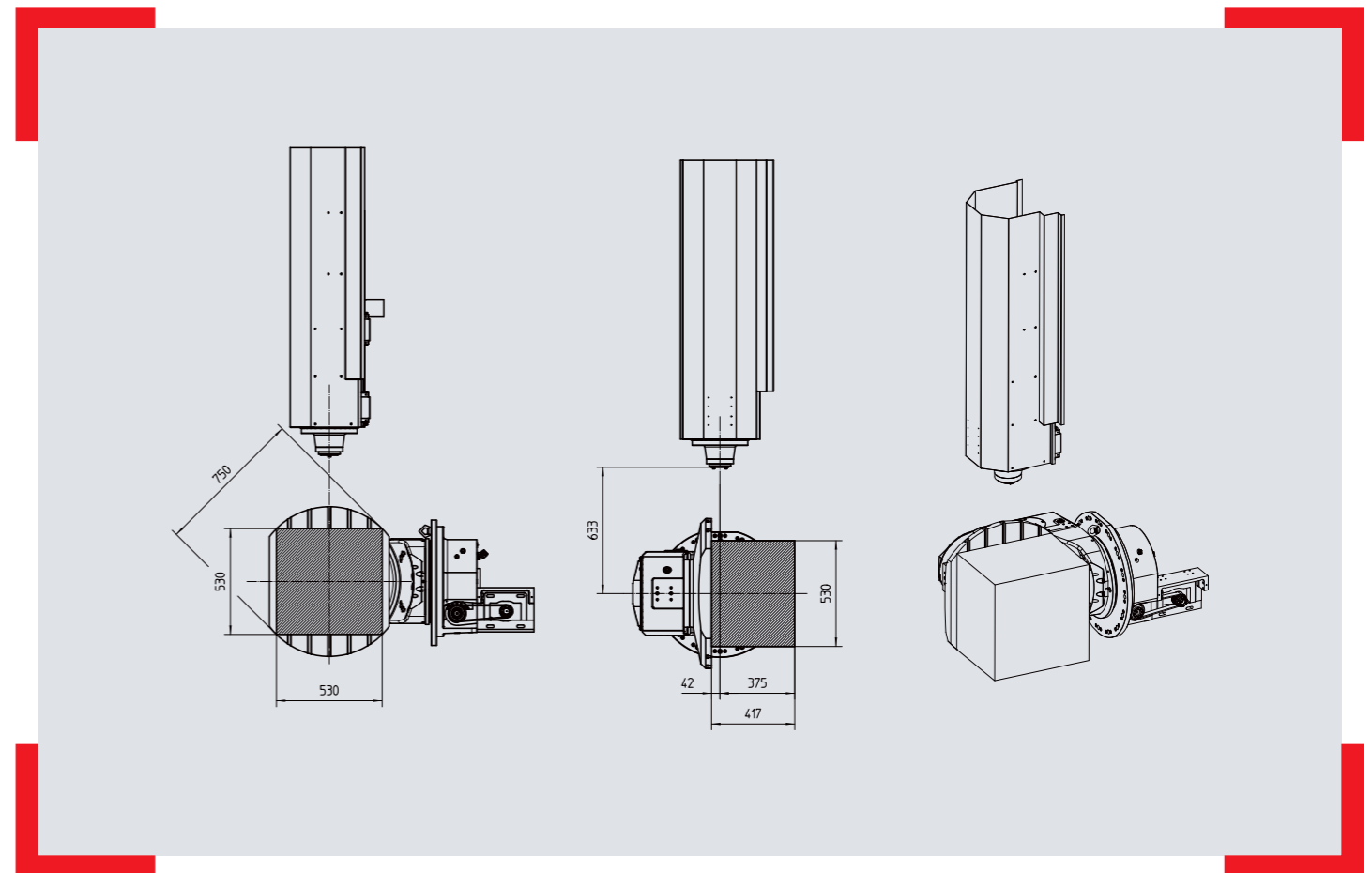

MAXXMILL 400 - 630 - 750

Technical data

Travel and tolerances	MAXXMILL 400	630	750
Travel in X	350 + 100 (13.8 + 3.9")	500 + 50 (19.6 + 1.9")	750 + 50 (29.5 + 1.9")
Travel in Y	250 mm (9.8")	460 mm (18.1")	610 mm (24")
Corsa asse Z	300 mm (11.8")	450 mm (17.7")	500 mm (19.6")
Distance spindle nose - table (min. - max. / mechanical spindle)	70 / 370 mm (2.8 / 14.6")	175 / 675 mm (6.8 / 26.5")	175 / 675 mm (6.8 / 26.5")
Distance spindle nose - table (min. - max. / motor spindle)	70 / 370 mm (2.8 / 14.6")	150 / 650 mm (5.9 / 25.5")	150 / 650 mm (5.9 / 25.5")
Swivel range B-axis	+/- 100°	+/- 100°	+/- 100°
Range of rotation C-axis (rotary table)	0 – 360°	0 – 360°	0 – 360°
Positioning accuracy P according to VDI 3441 *	10 µm	10 µm	10 µm
Positioning repeatability Ps according to VDI 3441 *	4 µm	4 µm	4 µm
Positioning accuracy B axis (tilting – with motor encoder)	36 sec	20 sec.	20 sec.
Positioning accuracy C axis (table – with motor encoder)	15 sec	10 sec.	10 sec.

Feed

Rapid motion speed X-Y-Z axis	30 m/min (1181.1 ipm)	30 m/min (1181.1 ipm)	30 m/min (1181.1 ipm)
Max. rotational speed B axis	20 rpm	16 rpm	25 rpm
Max. rotational speed C axis	25 rpm	20 rpm	25 rpm
Max. feed force X axis	3000 N (674.4 lbs)	5000 N (1124 lbs)	5000 N (1124 lbs)
Max. feed force Y axis	3000 N (674.4 lbs)	5000 N (1124 lbs)	5000 N (1124 lbs)
Max. feed force Z axis	3000 N (674.4 lbs)	5000 N (1124 lbs)	5000 N (1124 lbs)
Max. acceleration X-Y-Z axis	4 / 3 / 3 / m/s ²	3 m/s ²	3 m/s ²

Tilting table

Clamping area	∅ 400 mm (15.7")	630 x 500 mm (24.8 x 19.6")	750 x 600 mm (29.5 x 23.6")
Table-floor distance	860 mm (33.8")	855 mm (33.7")	805 mm (31.6")
Slot number	5	5	5
Distance between two T-slots	75 mm (2.9")	75 mm (2.9")	100 mm (3.9")
Groove wide	14 mm (0.55")	14 mm (0.55")	14 mm (0.55")
Max. workpiece weight (equally distributed)	80 kg (176 lb)	200 kg (440.9 lb)	300 kg (661,3 lb)
Max. permissible workpiece weight with counterbearing			500 kg (1102,3 lb)

Main spindle (mechanical spindle)

Speed range	50 – 12000 rpm	50 – 12000 rpm	50 – 12000 rpm
Maximum spindle torque	33 Nm (30.2 ft/lbs)	100 Nm (73.8 ft/lbs)	100 Nm (73.8 ft/lbs)
Maximum spindle power	7 kW (9.4 hp)	15 kW (20.1hp)	15 kW (20.1hp)
Tool taper	ISO 30 DIN 69871	ISO 40 DIN 69871	ISO 40 DIN 69871
Pull stud	DIN 69872A	ISO 7388/2 Type B	ISO 7388/2 Type B
Drive	direct drive	direct drive	direct drive

Main spindle (motor spindle)	MAXXMILL 400	630	750
Speed range	50 – 24000 rpm	50 - 15000 rpm	50 - 15000 rpm
Maximum spindle torque	38 Nm (27.9 ft/lbs)	100 Nm (73.8 ft/lbs)	100 Nm (73.8 ft/lbs)
Maximum spindle power	16 kW (21.5 hp)	20 kW (26.8 hp)	20 kW (26.8 hp)
Tool taper	HSK-A40	ISO 40 (HSK-A63)	ISO 40 (HSK-A63)

Tool magazine

Number of tool stations	30 ISO 30 30 HSK-A40	30 (60)	30 (40 / 60)
Tool changing type	double arm gripper	double arm gripper	double arm gripper
Tool management	Random	Random	Random
Tool changing time (tool-tool)	2 Sek.	2 sec.	2 sec.
Max. tool diameter	63 mm (2.5")	80 mm (3.1")	80 mm (3.1")
Max. tool diameter (without neighbouring tools)	100 mm (3.9")	125 mm (4.9")	125 mm (4.9")
Max. tool length	200 mm (7.9")	250 mm (9.8")	250 mm (9.8")
Max. tool weight	5 kg (11.0 lb)	8 kg (17.6 lb)	8 kg (17.6 lb)
Total tool weight supported by the magazine	70 kg (154.3 lb)	100 kg (220.5 lb)	100 kg (220.5 lb)

Coolant tank

Tank capacity	120 l (31.7 gal)	200 l (52.8 gal)	250 l (60 gal)
Standard pump pressure	2 bar (29.0 PSI)	2 bar (29.0 PSI)	2 bar (29.0 PSI)
Max. capacity at 2 bar	40 l/min (10.6 gal/min)	40 l/min (10.6 gal/min)	40 l/min (10.6 gal/min)

Pneumatic supply

Min. pressure supply	6 bar (79.8 PSI)	6 bar (79.8 PSI)	6 bar (79.8 PSI)
Min. capacity required	200 NI/min	200 NI/min	200 NI/min

Lubrication

Spindle	Grease	Grease	Grease
Linear roller ways	Oil / central lubrication	Grease	Grease
Ball screws	Oil / central lubrication	Grease	Grease

Abmessungen

Total height	2300 mm (90.6")	3060 mm (120.4")	3060 mm (120.4")
Dimensions L x D without chip conveyer	1630 x 2300 mm (64.2 x 90.6")	2500 x 3120 mm (98.4 x 122.8")	2770 x 3350 mm (109 x 131.8")
Weight	3300 kg (7.275 lb)	4800 kg (10582.2 lb)	7900 kg (17416.52 lb)

* Values measured at a temperature of 22°C, with the machine mounted on the floor. Machine, with linear scales - pitch compensated with laser, and motor encoders in the rotary axis.

